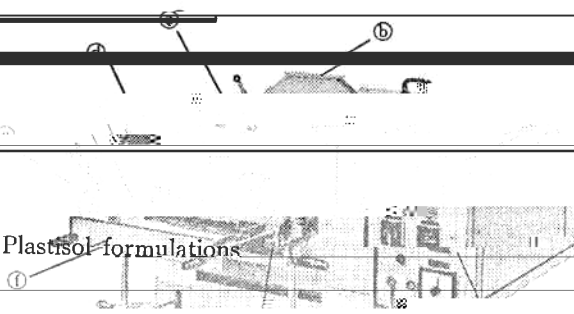
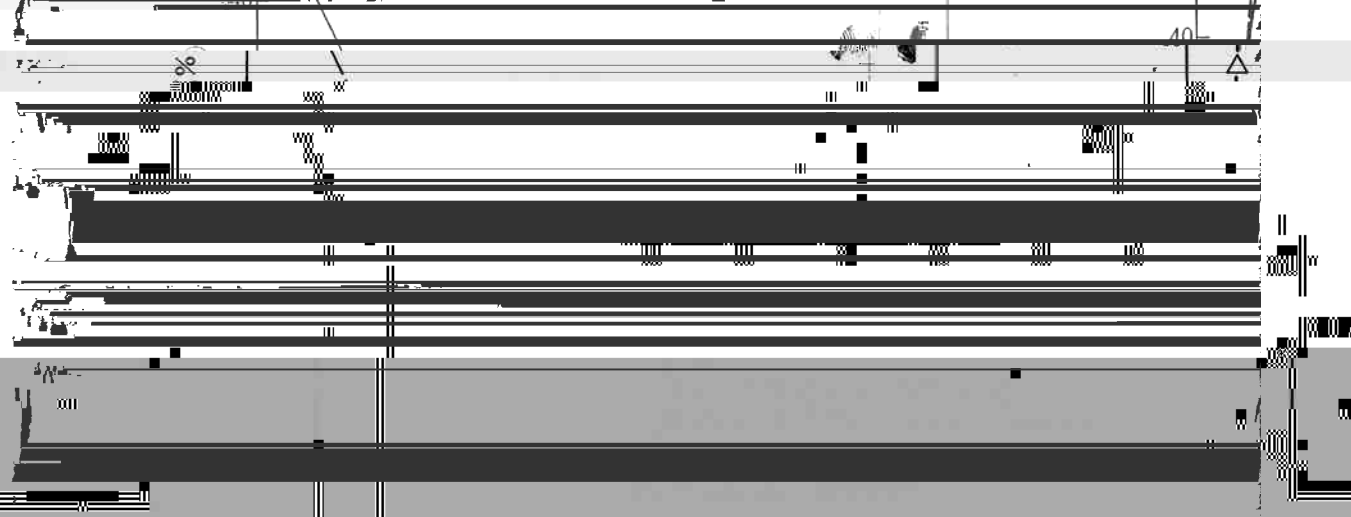
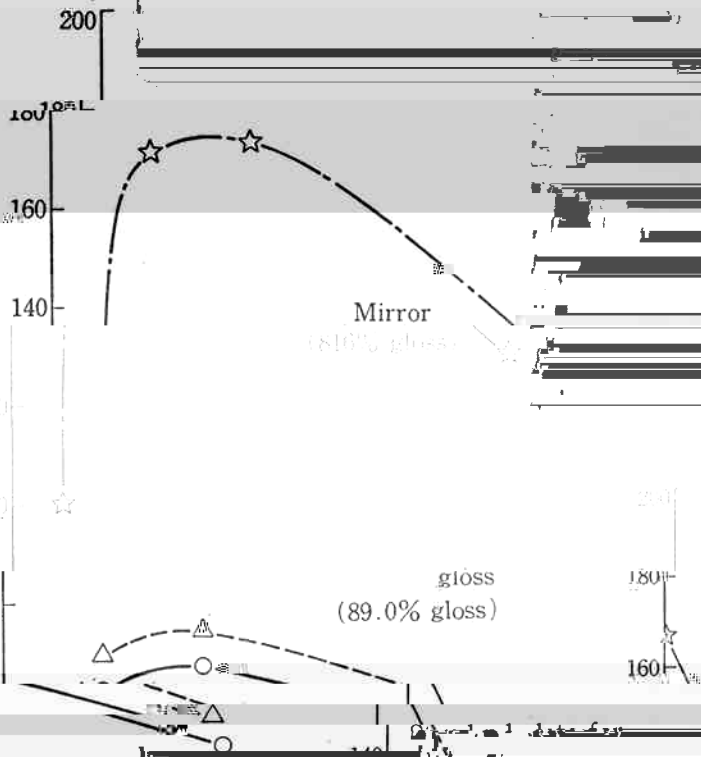
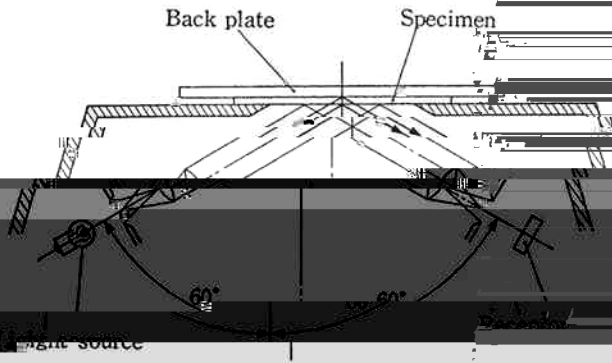

Table 2 Plastisol formulations



Plastic resin

PP 表面層単独シートの成形



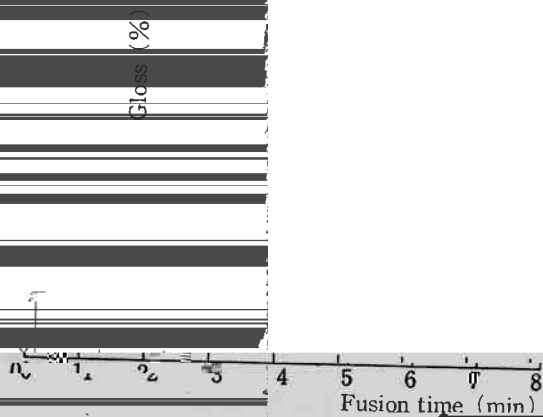
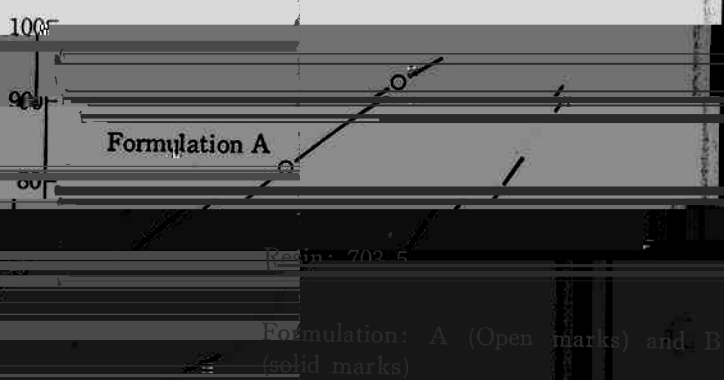

Fig. 5 Change of surface gloss



Formulation: A (Open marks) and B (solid marks)

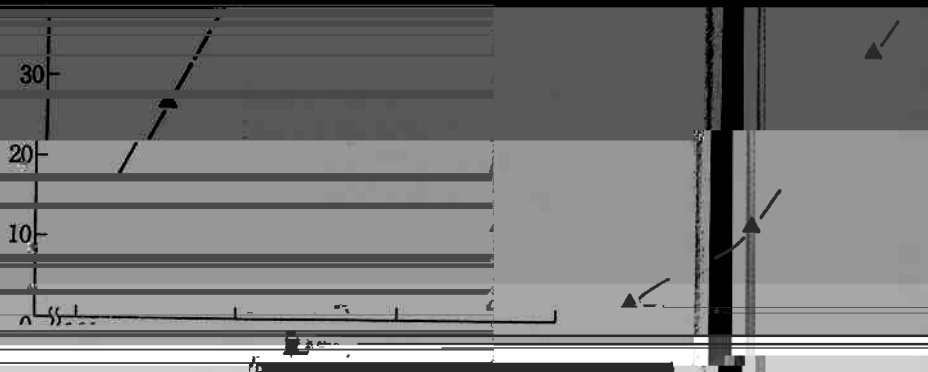
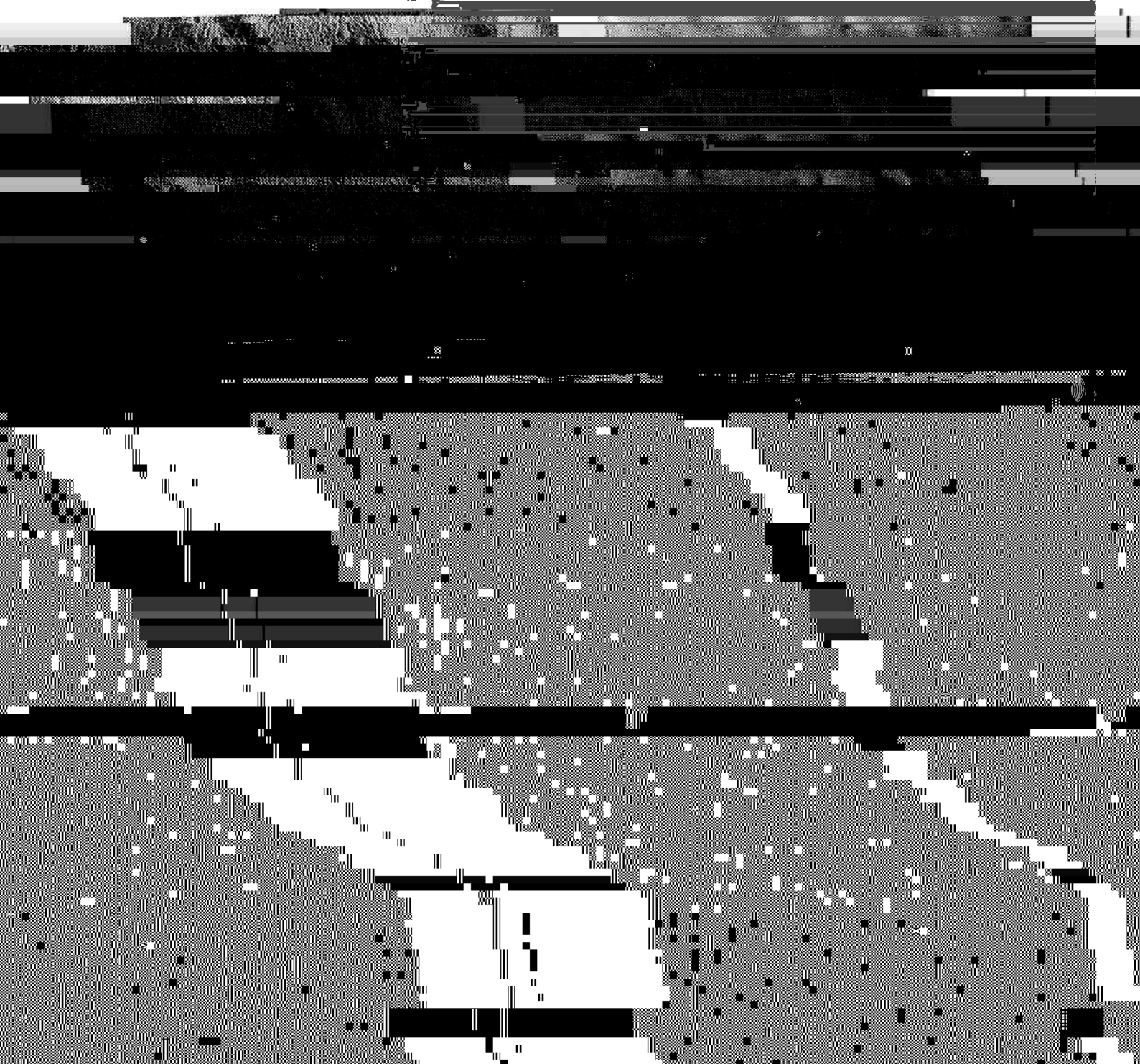

Fig. 7. Micrographs showing the surface roughness in fusion process of toncoat resin.



(c)

(f)

7. Micrographs showing the surface roughness in fusion process of toncoat resin

The diagram shows a cross-section of a layered structure. A central vertical dashed line runs through the middle. On either side of this line, there are several horizontal layers. From top to bottom, the layers consist of: a thin white layer, a thin black layer, a thicker white layer, a thin black layer, a thin white layer, a thin black layer, and a thick white layer. The overall structure is symmetrical about the central dashed line.

ベースト塩ビシート表面光沢

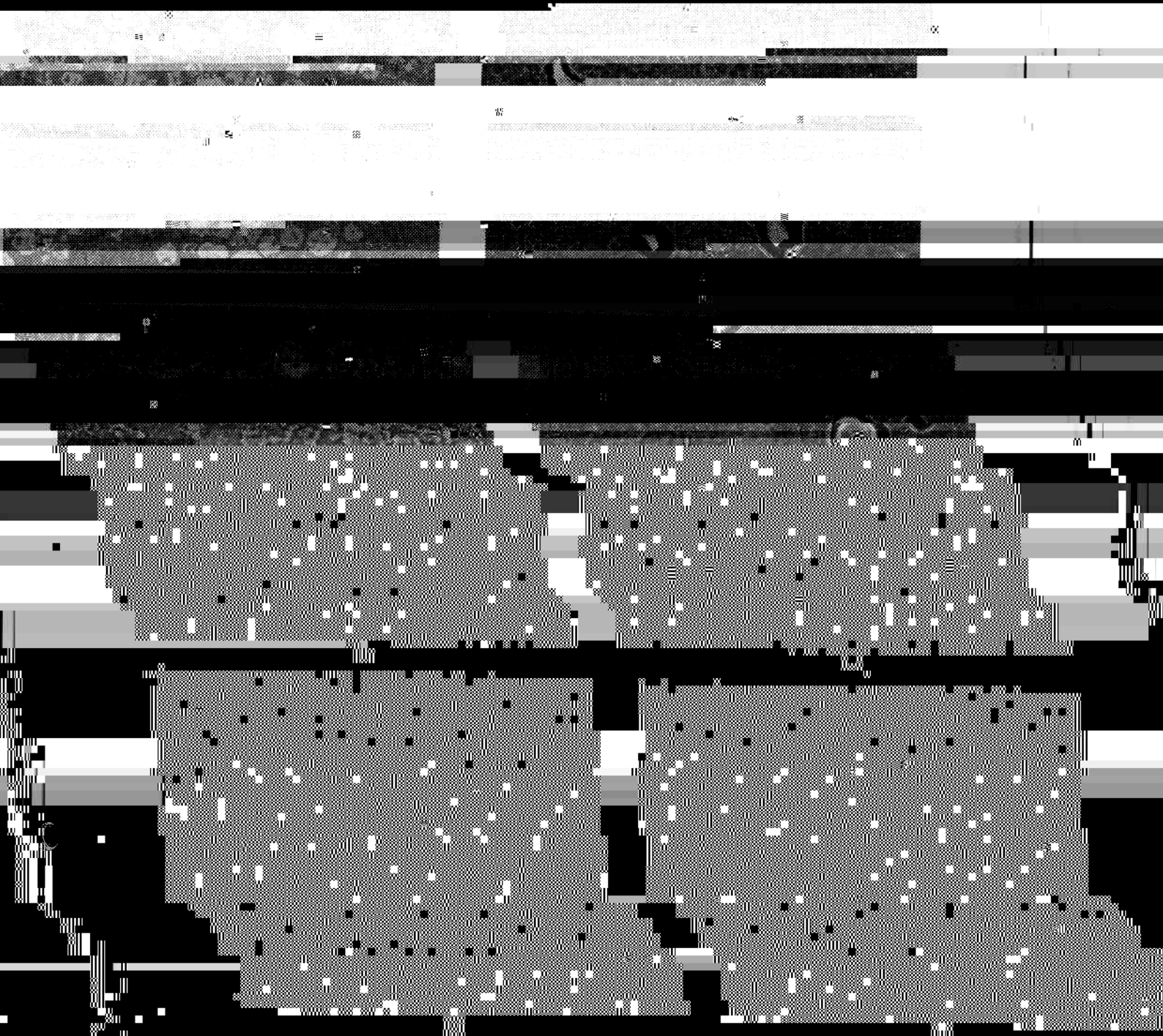
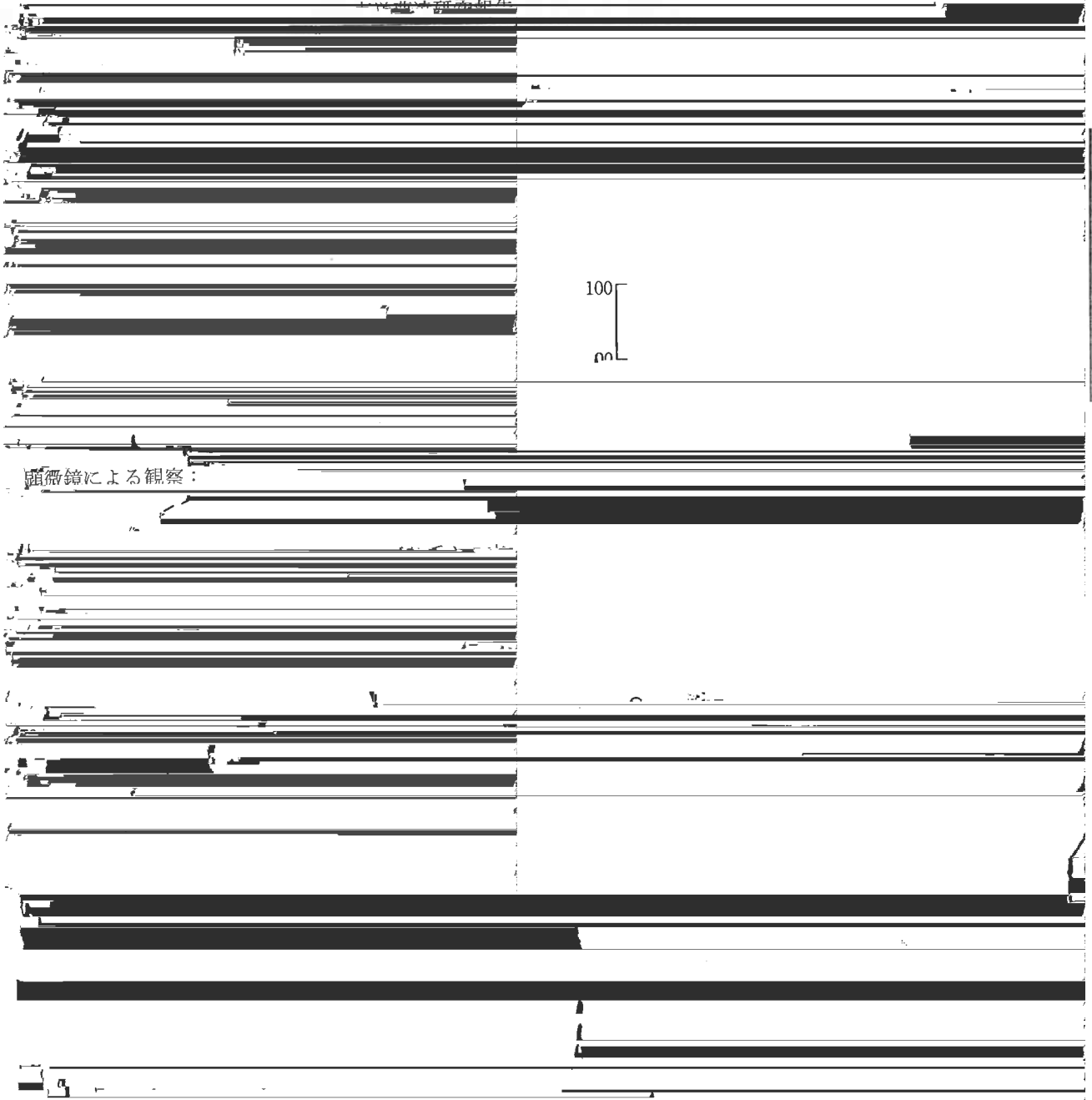

Fig. 8. Microscopic observation of PVC sheet surface.



顕微鏡による観察:

100
00



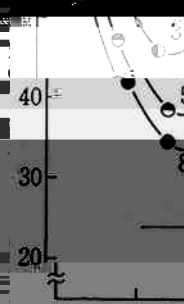
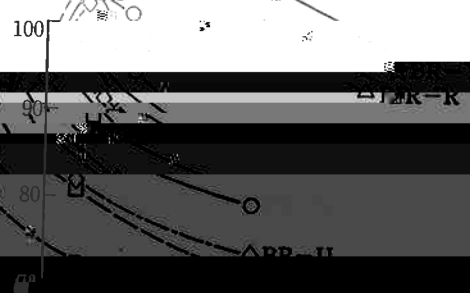
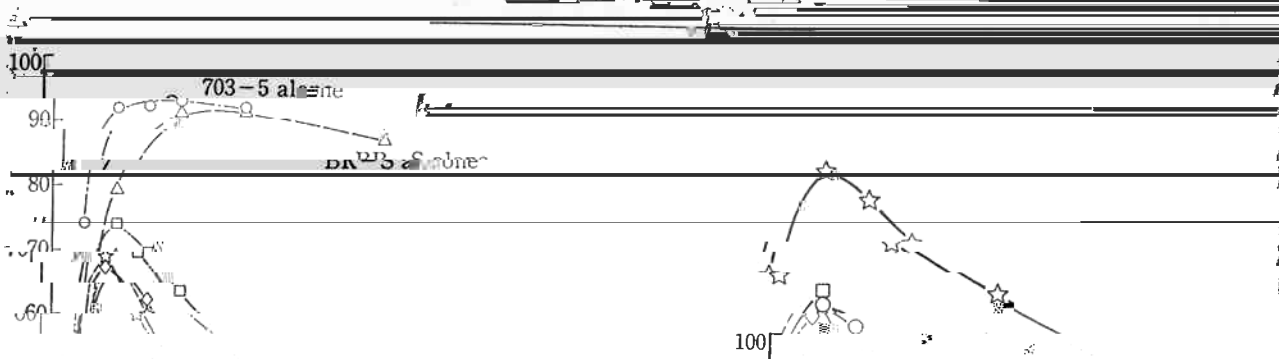

100
100

gloss

346 Drill: Approved Cont: Surface: 100

P

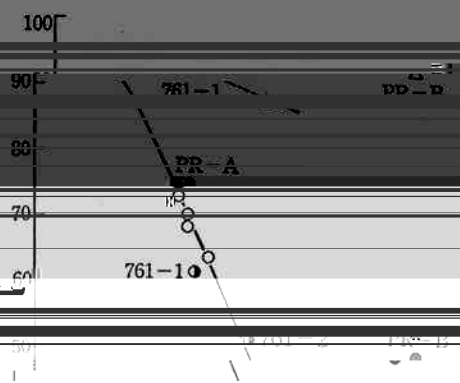

10000

7-27-67

BB.P. M. S. 000 0.54 44 90 60 60

くなるにつれて、そのブレンド物の表面グロスは低下

正付と入内とに

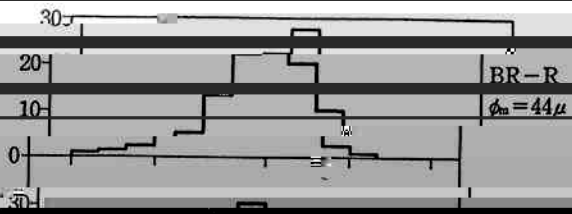

BR-S
 $\phi_m = 38\mu$

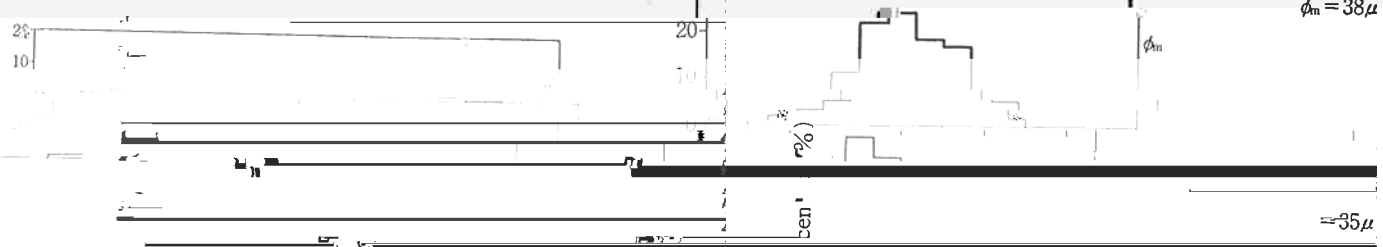

$\phi_m = 36\mu$

BR-X
 $= 60\mu$

725-4

80

0 0.1 0.2 0.3 0.4 0.5 0.6

Thickness of topcoat layer (mm in dry)



Thickness of topcoat layer (mm in dry)

